

Infrared Point Source LED Chip MED8P51

MED8P51 is a low failure rate infrared point source LED chip optimized for optical switches, encoders and other light source applications due to its track-shaped emitting aperture.

• Features

- Track-shaped emitting aperture ($\phi 160 \times 40\mu\text{m}$)
- High output power
- High reliability

• Structure

- Material: AlGaAs/GaAs sub.
- Electrode: Au alloy (p, n)
- Emitting surface: p side

• Applications

- Optical encoders
- Optical switches
- Optical sensors etc

• Absolute Maximum Ratings*(Ta=25°C)

Parameter	Symbol	Rating	Unit
Power Dissipation	P_D	150	mW
Forward Current	I_F	80	mA
Reverse Voltage	V_R	3	V
Operating Temperature	T_{opr}	-20 ~ 80	°C
Storage Temperature	T_{stg}	-30 ~ 100	°C

• Electro-Optical Characteristics*(Ta=25°C)

Parameter	Symbol	Condition	Min.	Typ.	Max.	Unit
Forward Voltage	V_F	$I_F=50\text{mA}$	-	2.0	3.0	V
Reverse Current	I_R	$V_R=3\text{V}$	-	-	10	μA
Output Power	P_o	$I_F=50\text{mA}$	1.2	2.0	-	MW
Peak Wavelength	λ_p	$I_F=50\text{mA}$	-	850	-	nm

* as mounted on TO18 header and hermetically sealed

• Dimensional outline drawing (μm)

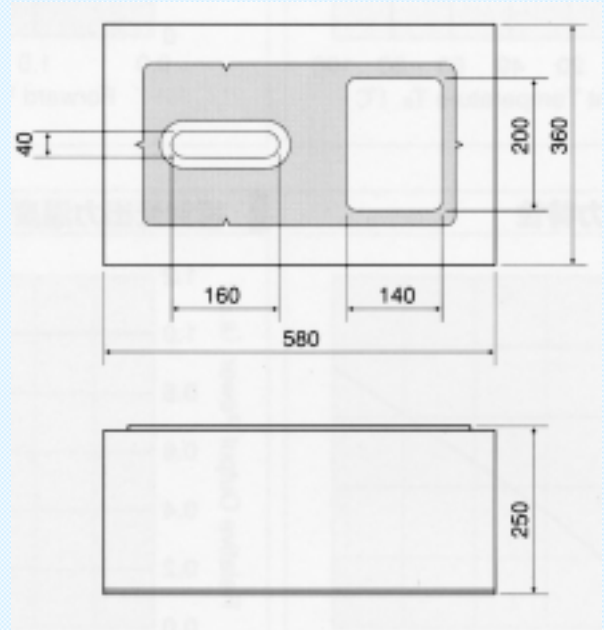

Star LED



Daido Steel Co., Ltd

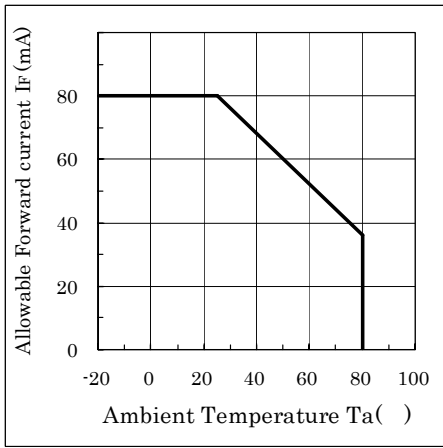

Fig1. I_F / T_a

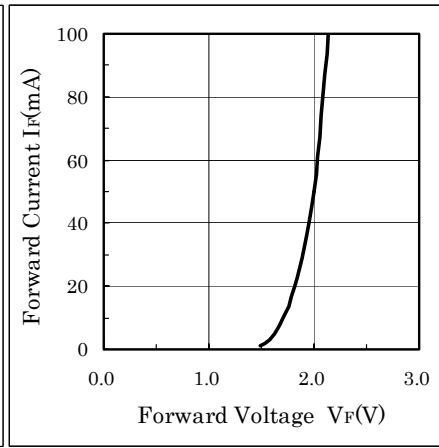

Fig2. I_F / V_F

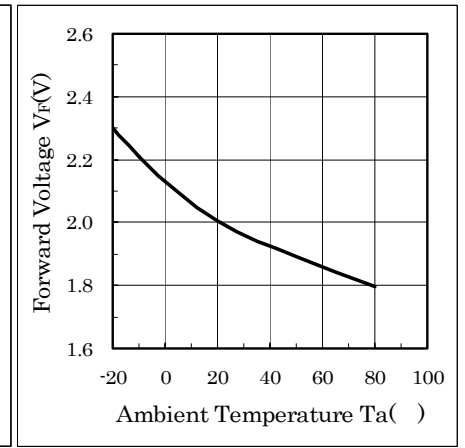

Fig3. V_F / T_a

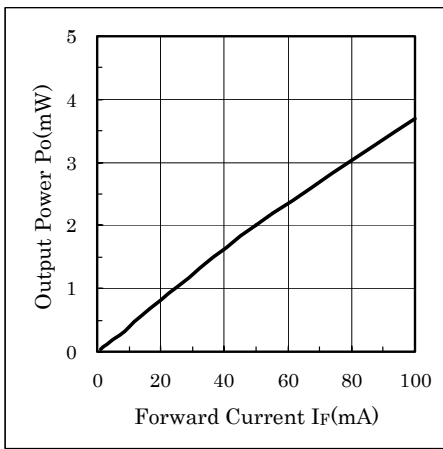

Fig4. P_o / I_F

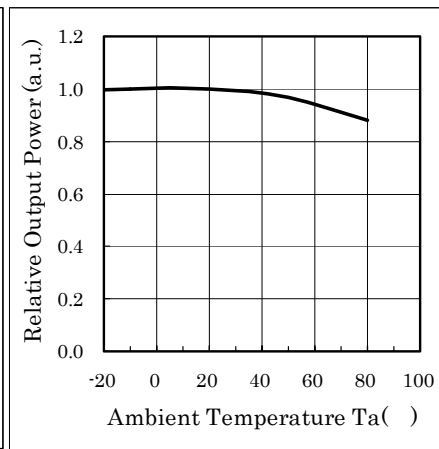

Fig5. Relative P_o / T_a

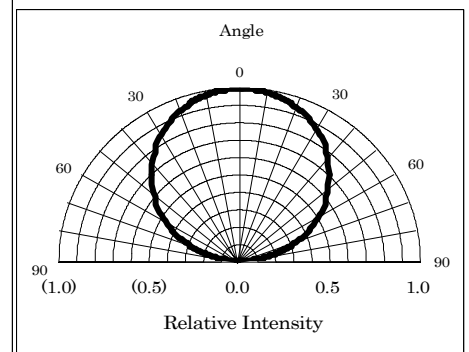

Fig6. Spatial Distribution

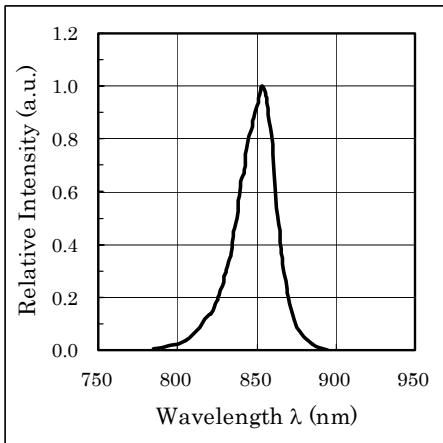

Fig7. Spectral Characteristics

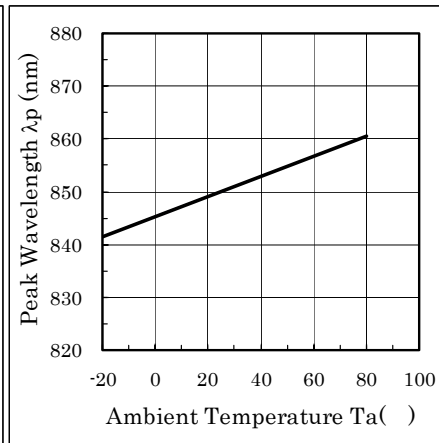

Fig8. Peak Wavelength / T_a

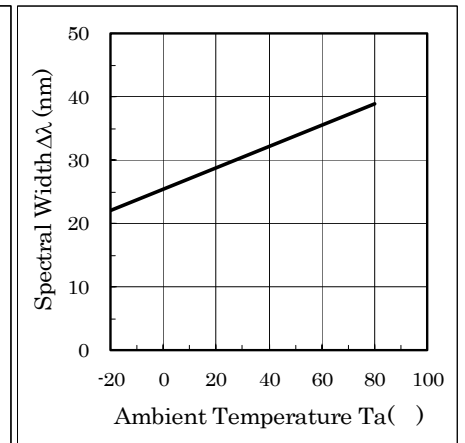

Fig9. Spectral Width / T_a

This catalogue was compiled in September 2003. All items listed in the catalogue are subject to change without any prior notice.

Products listed in this catalogue are manufactured for use in standard applications (eg: household appliances, OA/AV, telecommunications, measurement instruments). Please do not use the products in critical reliability and security applications (eg: space and aviation, critical-safety transport applications, nuclear power control, medical, life-supporting units and equipment).



DAIDO STEEL Co., Ltd.

New Business Development Center

6-35, Konan 1-chome, Minato-ku, Tokyo 108-8478, Japan

TEL:+81 3 5495 1255 FAX:+81 3 5495 6734 URL:<http://www.daido.co.jp>